

CPM-12

Multifunction Power Meter Manual



Content

1. Product Overview.....	1
2. Specifications.....	1
3. Wiring Instruction.....	2
4. General Operation.....	5
5. Programming Setting.....	9
6. RS485 Communication Table.....	15

CPM-12 Manual

1. Product Overview

Description

CPM-12 multifunction power meter provide high accuracy single phase and three-phase measuring and displaying, energy accumulating, power quality analysis, and data communication. It provides power demand and maximum demand records for power and current. Hardware can be option a RS485 Modbus communication port.

2. Specifications

Panel Description

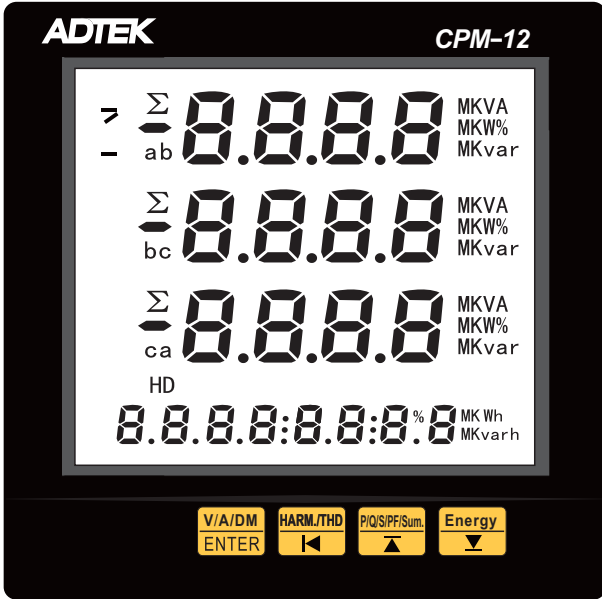

Display	Description
Three line of 8 digits in the metering area	Display metering data such as voltage \ current \ Demand \ power factor \ unbalance \ etc.
MKVA \ MKW \ MKvar \ %	Display metering data unit
a \ b \ c	a, b, c for 3 phase
ab \ bc \ ca	a-b, b-c, c-a for 3 phase line to line
Eight 8	Display energy value
MKWh \ MKvarh	Display energy unit
HD	THD of Voltage / Current
Σ	Summary or Average
\rhd	Communication indicator icon
-	Wiring changed

- V/A/DM ENTER** Enter / Confirm
Quickly index: Voltage / Current / Demand
- HARM./THD** Shift input position / Press 2sec back to previous menu
Quickly index: THD
- P/Q/S/PF/Sum** Up / Number increase
Quickly index: Power parameters
- Energy** Down / Number decrease
Quickly index: Energy parameters

Dimensions & Installation

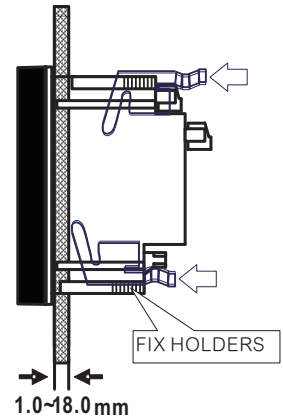
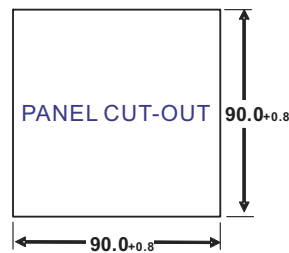
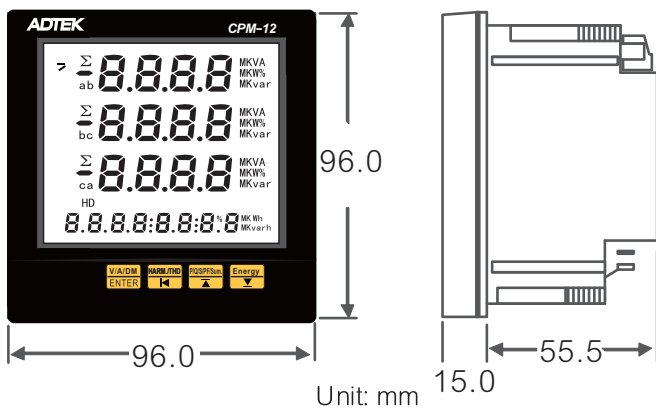

AUX Power

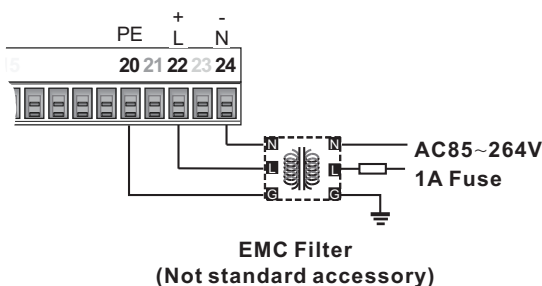

RS485 Communication port

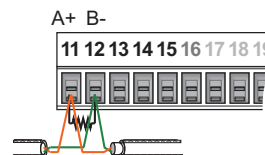

Max Distance: 1200M
Terminal Resistors
suggested : 120Ω/0.5W
(Not standard accessory)

Terminal block

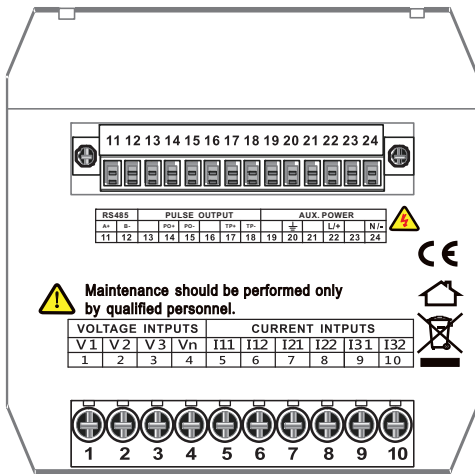

Pulse Output

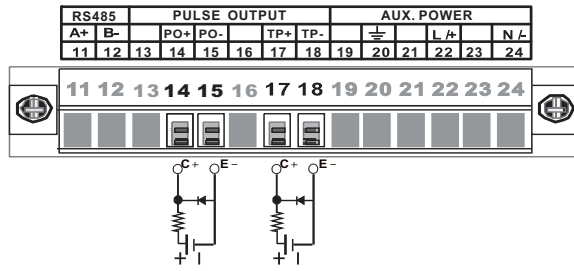

3. Wiring Instruction

Voltage and current wiring

(CT secondary side distinguishes 1A/5A and 333mV)

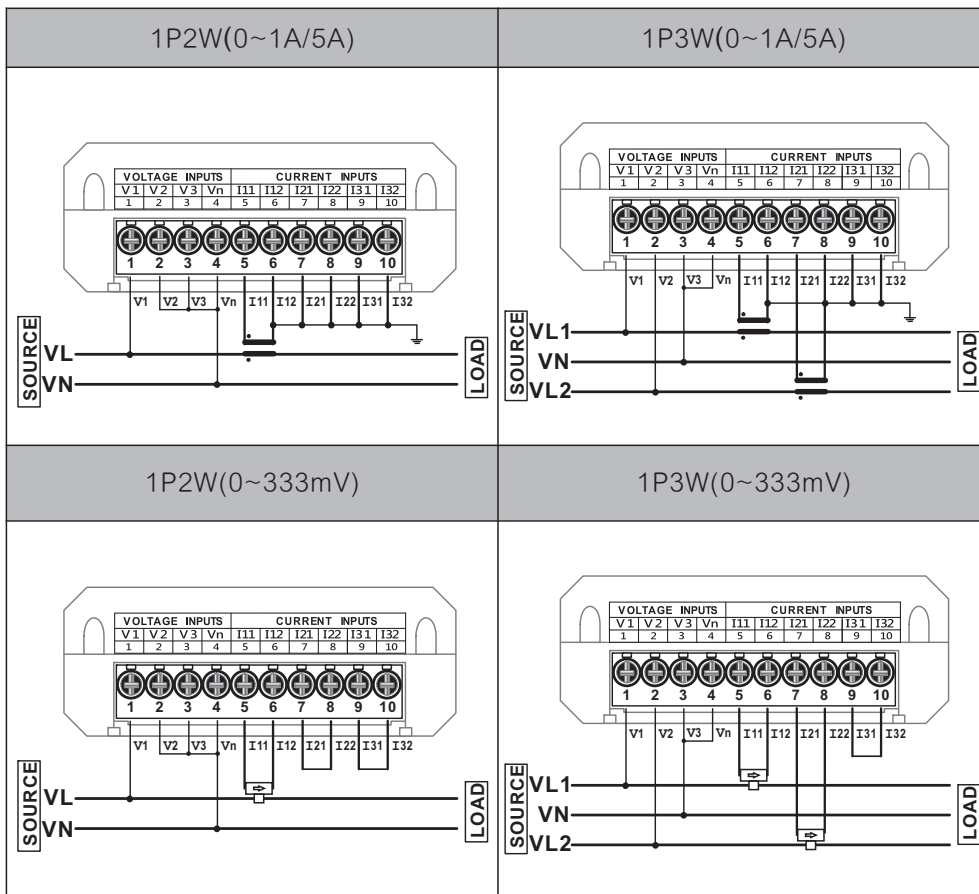

3P3W W/O PT

3CT(0~1A/5A)

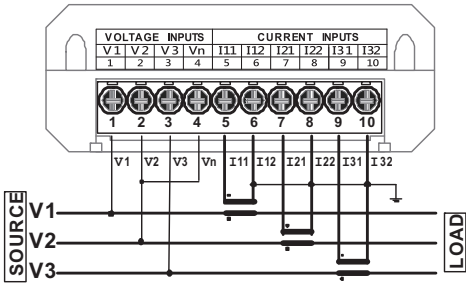

2CT(0~1A/5A)

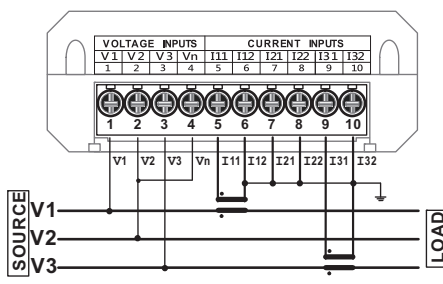

1CT(0~1A/5A)

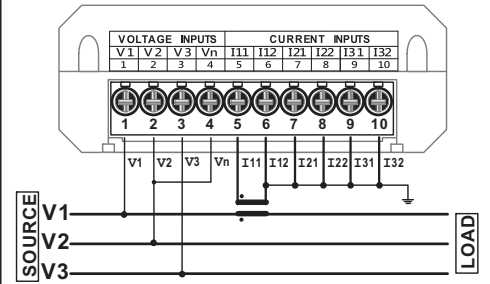

3CT(0~333mV)

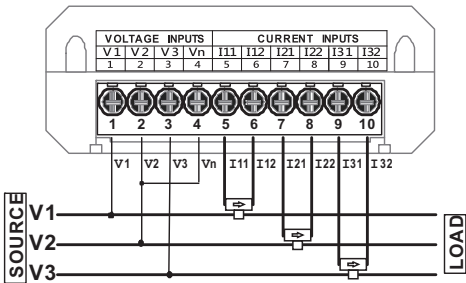

2CT(0~333mV)

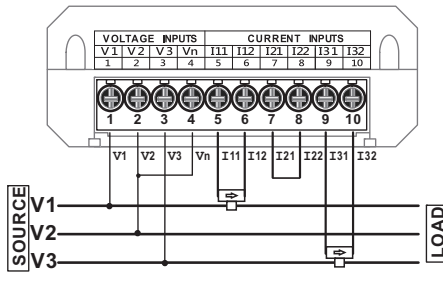

1CT(0~333mV)

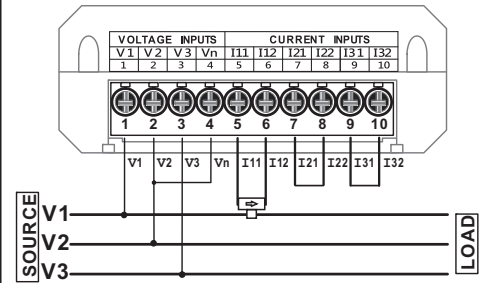

3P3W 2PT

3CT(0~1A/5A)

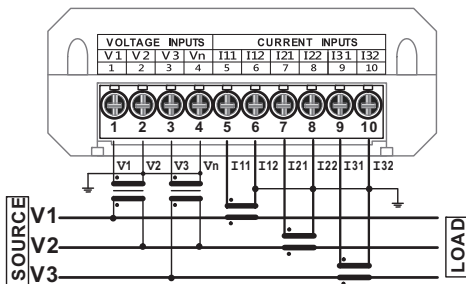

2CT(0~1A/5A)

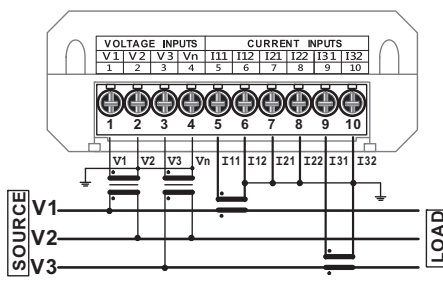

1CT(0~1A/5A)

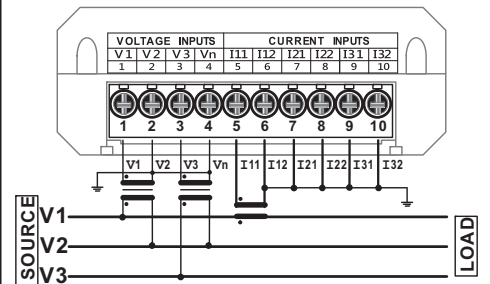

3CT(0~333mV)

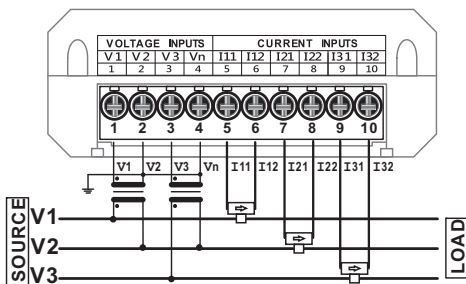

2CT(0~333mV)

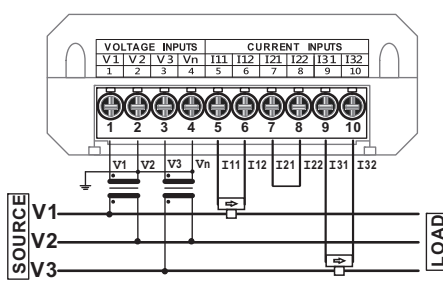

1CT(0~333mV)

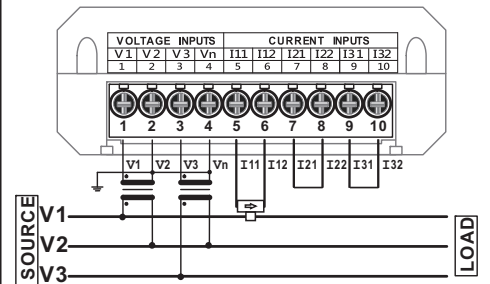

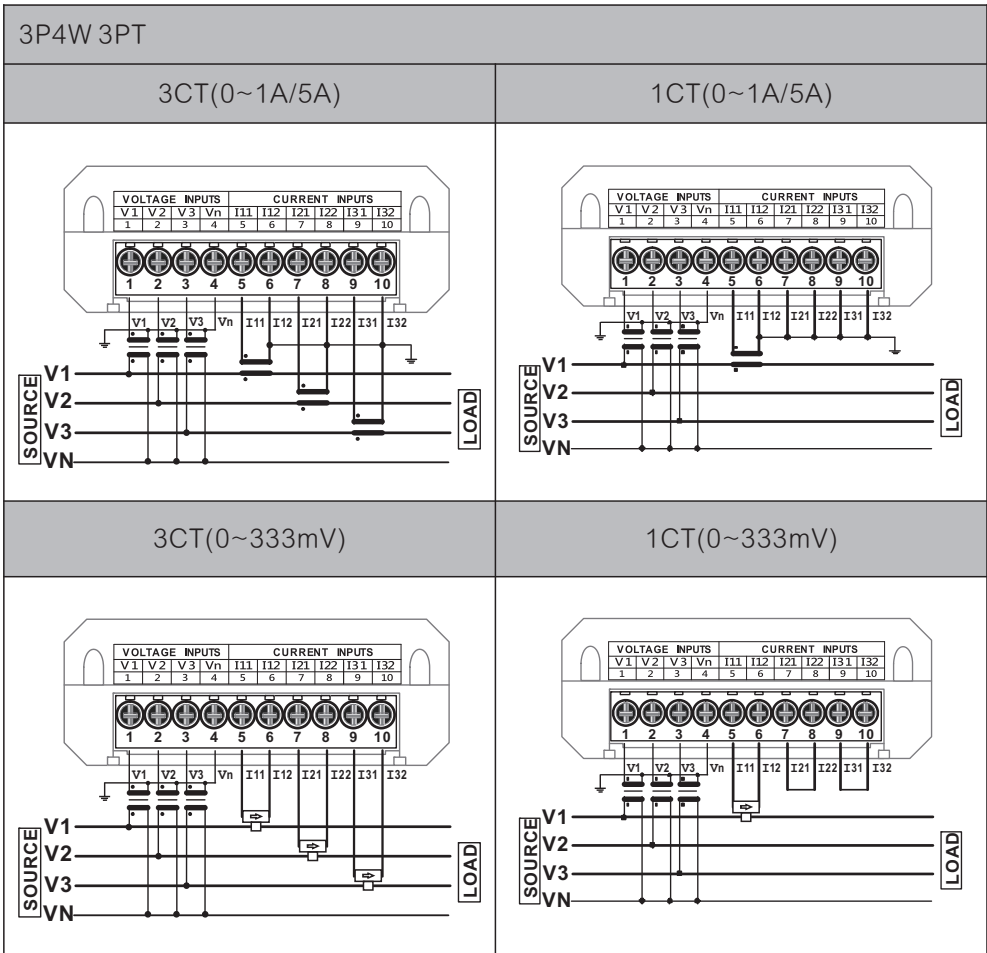
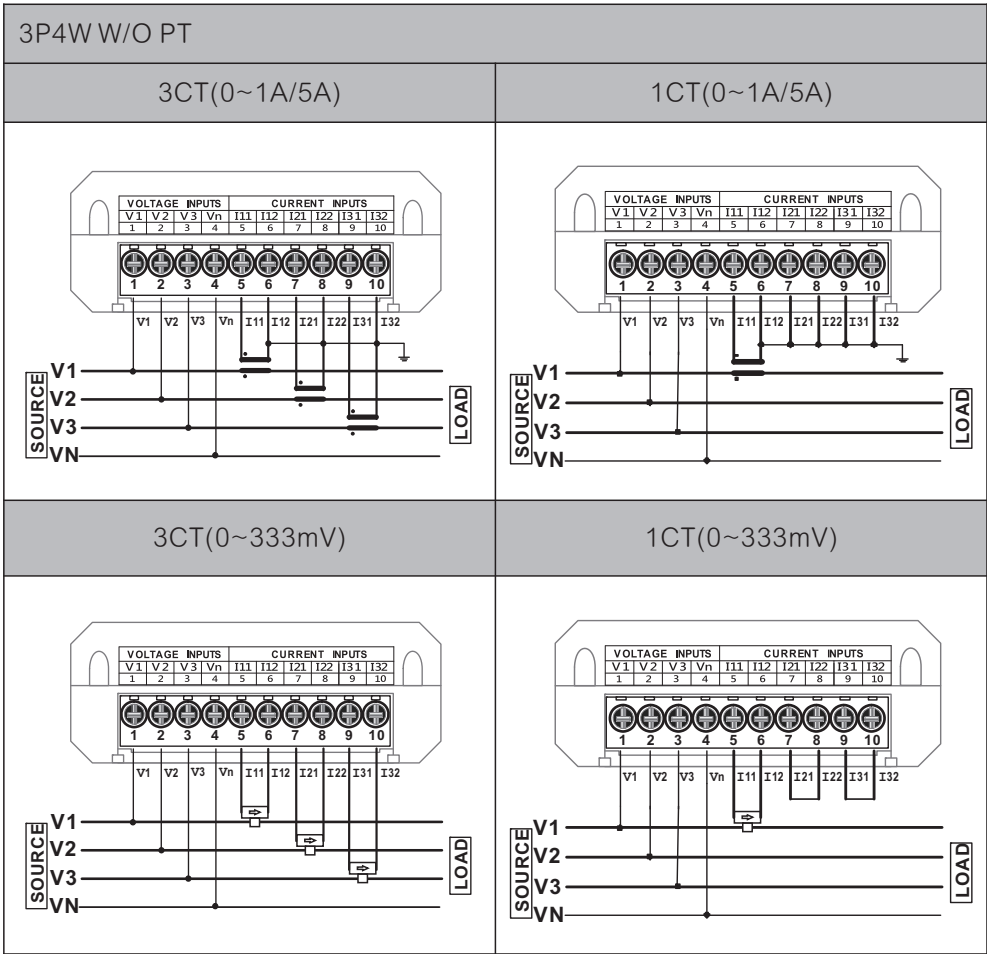

4. General Operation

Operational flow chart

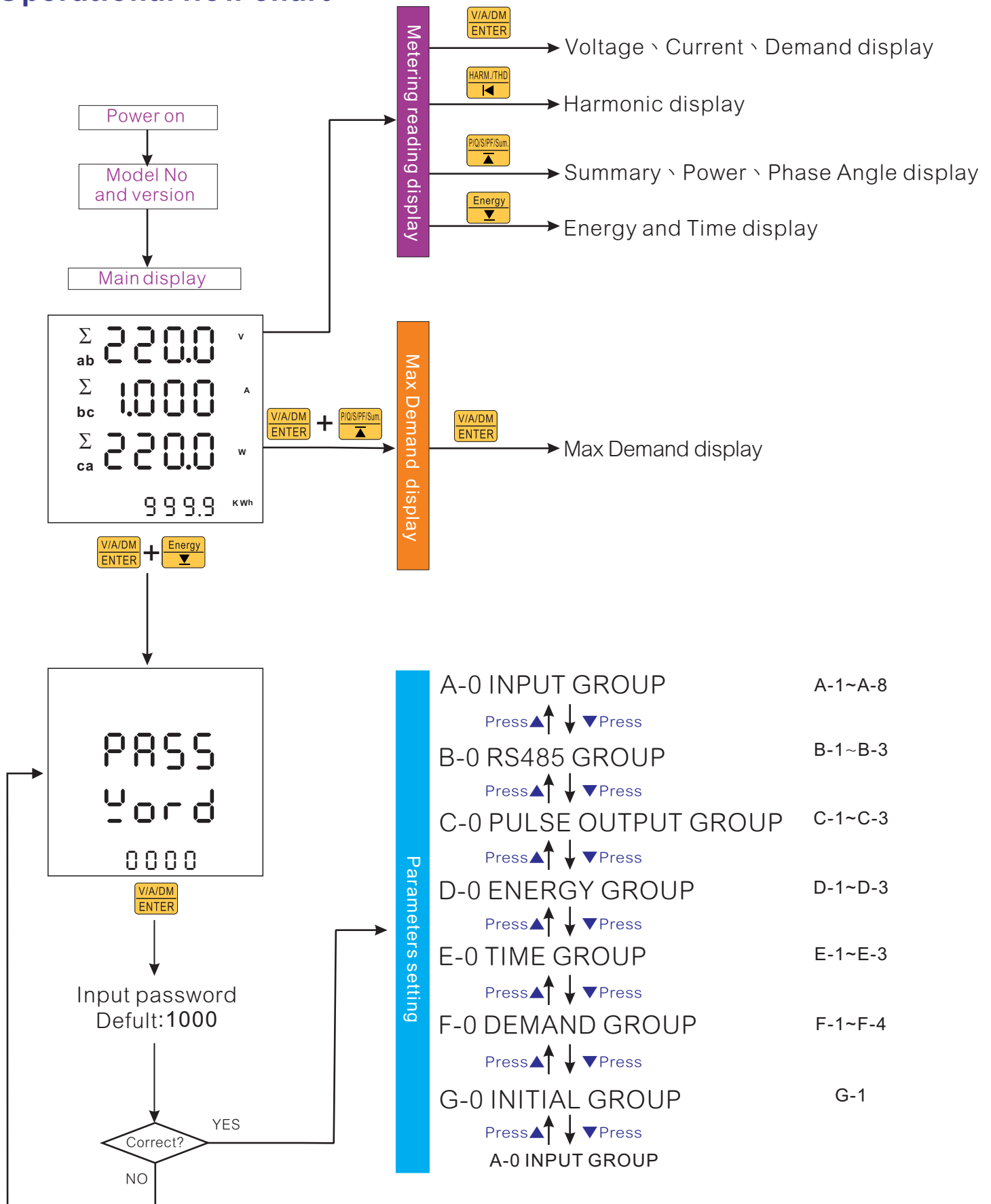

Voltage/Current/Demand display

Press **V/A/DM**
ENTER

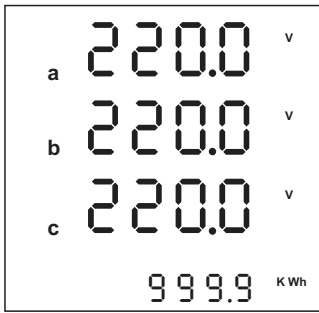

Each phase voltage

V/A/DM
ENTER

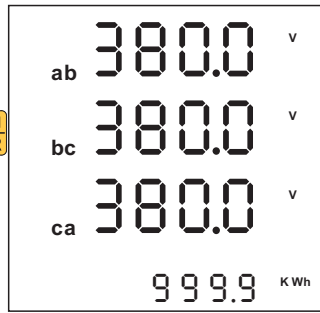

Each line voltage

V/A/DM
ENTER

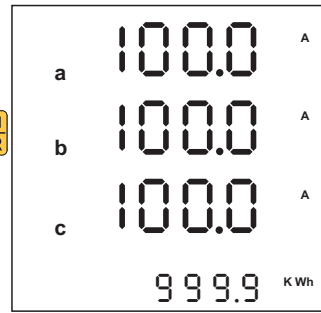

Each phase current

V/A/DM
ENTER

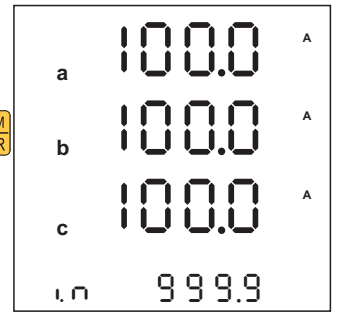

Current & Neutral current

V/A/DM
ENTER

Back to each phase voltage

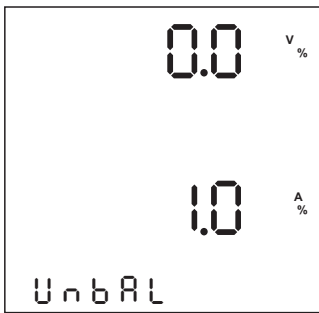

Voltage/
Current unbalance

V/A/DM
ENTER

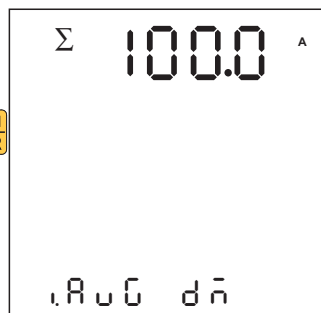

Average current demand

V/A/DM
ENTER

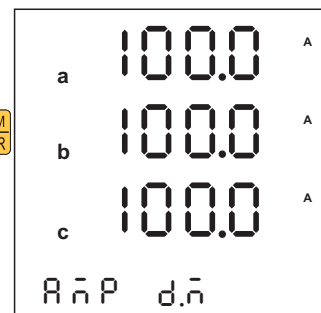

Current demand

V/A/DM
ENTER

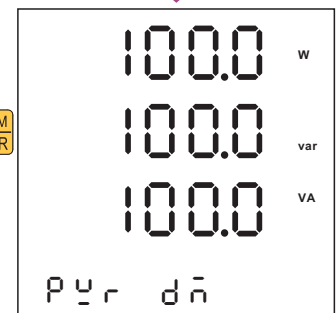

Power demand

V/A/DM
ENTER

Total harmonic display

Press **HARM./THD**

System type:
1P2W/1P3W/
3P4W1CT/
3P4W3CT

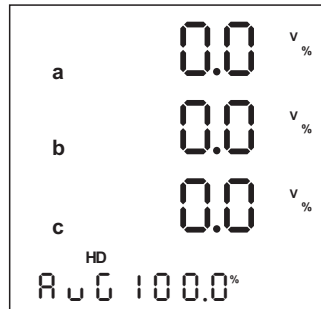

Each phase voltage
harmonic & Average
phase voltage harmonic

HARM./THD

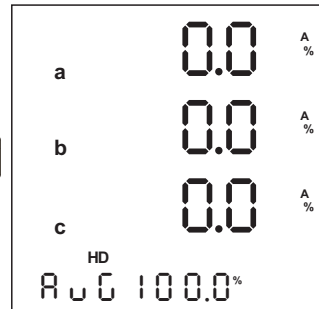

Current harmonic &
Average current
harmonic

System type:
3P3W1CT/
3P3W2CT/
3P3W3CT/

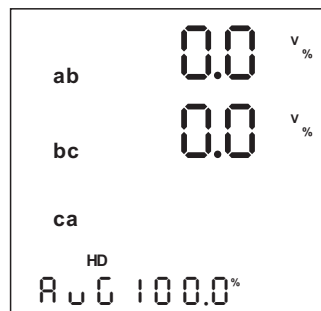

Each line voltage
harmonic & Average line
voltage harmonic

HARM./THD

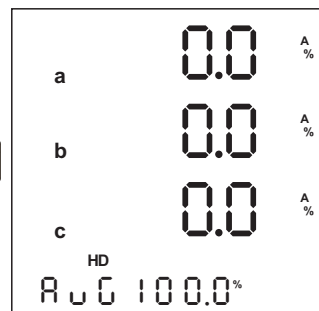

Current harmonic &
Average current
harmonic

Summary \ Power \ Phase Angle display

Press 

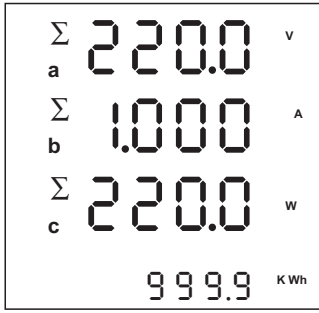

Summary-0
Phase voltage/ Current/
Active power/
IMP active energy

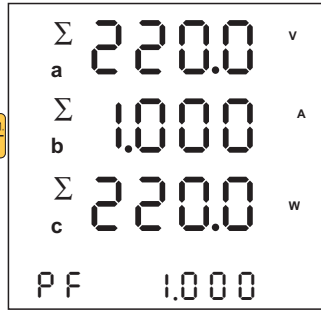

Summary-1
Phase voltage/ Current/
Active power/
PF

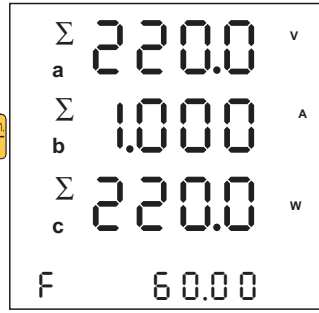

Summary-2
Phase voltage/ Current/
Active power/
Frequency

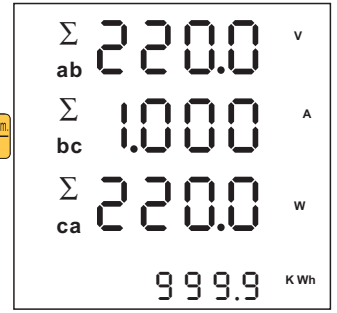

Summary-3
line voltage/ Current/
Active power/
IMP active energy

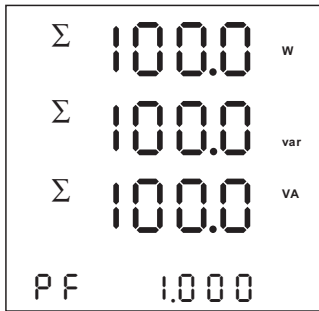

Summary-7
Active power/
Reactive power/
Total apparent power/
PF

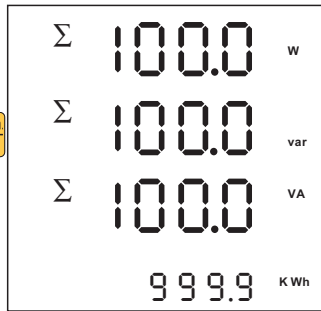

Summary-6
Active power/
Reactive power/
Total apparent power/
IMP active energy

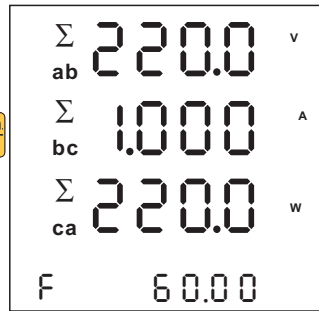

Summary-5
line voltage/ Current/
Active power/
Frequency

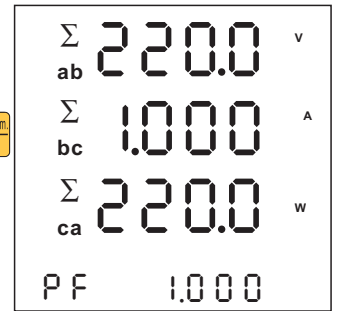

Summary-4
line voltage/ Current/
Active power/
PF

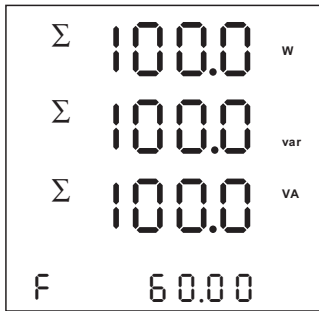

Summary-8
Active power/
Reactive power/
Total apparent power/
Frequency

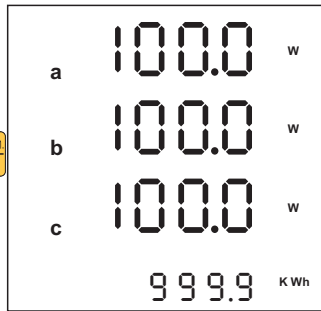

Each phase
active power/
IMP active energy

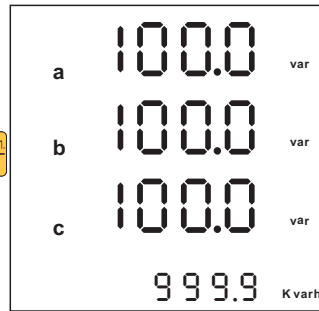

Each phase
reactive power/
IMP reactive energy

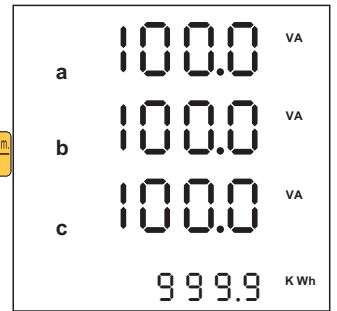

Each phase
apparent
power/
IMP active energy

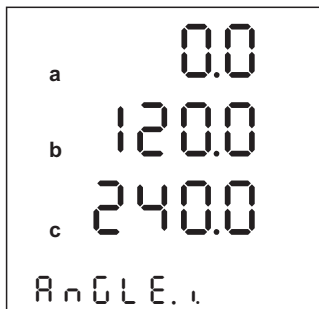

Current phase angle
I1-V1(V12)
I2-V1(V12)
I3-V1(V12)

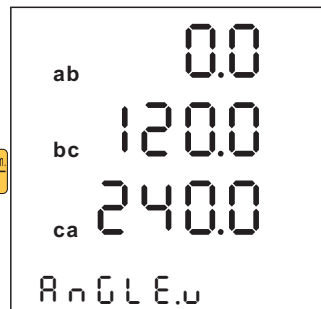

line voltage
phase angle
V12-V12
V23-V12
V31-V12

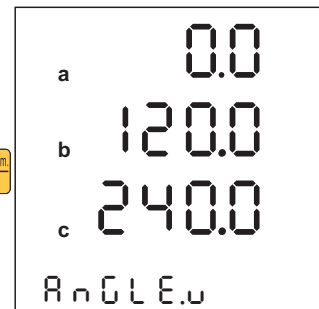

Phase voltage
phase angle
V1-V1
V2-V1
V3-V1

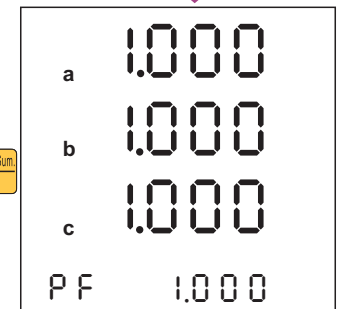

Each phase power factor/
Average power factor

Back to Summary-0

Energy and Time display

Press 

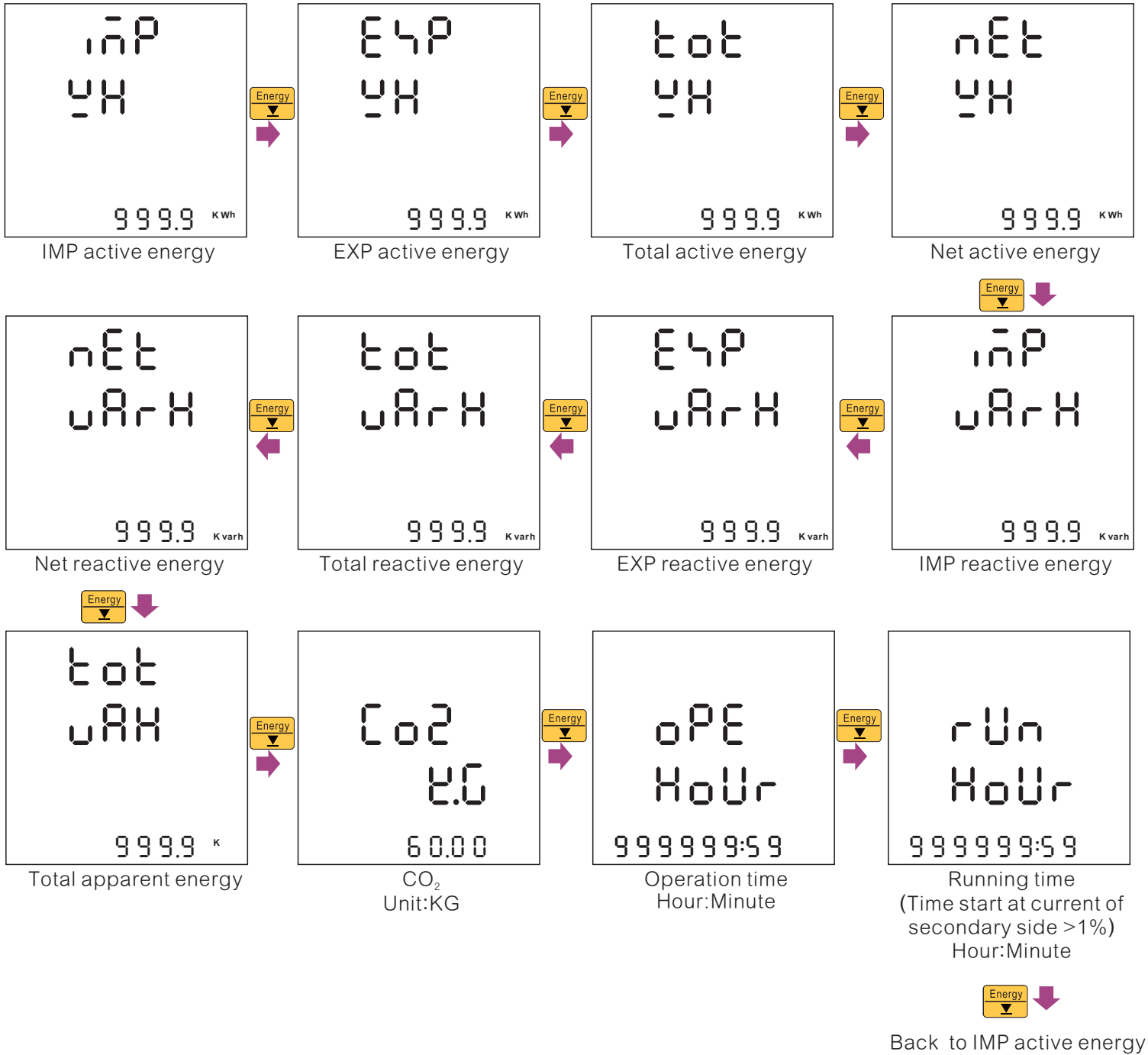

Max demand display

Press  + 

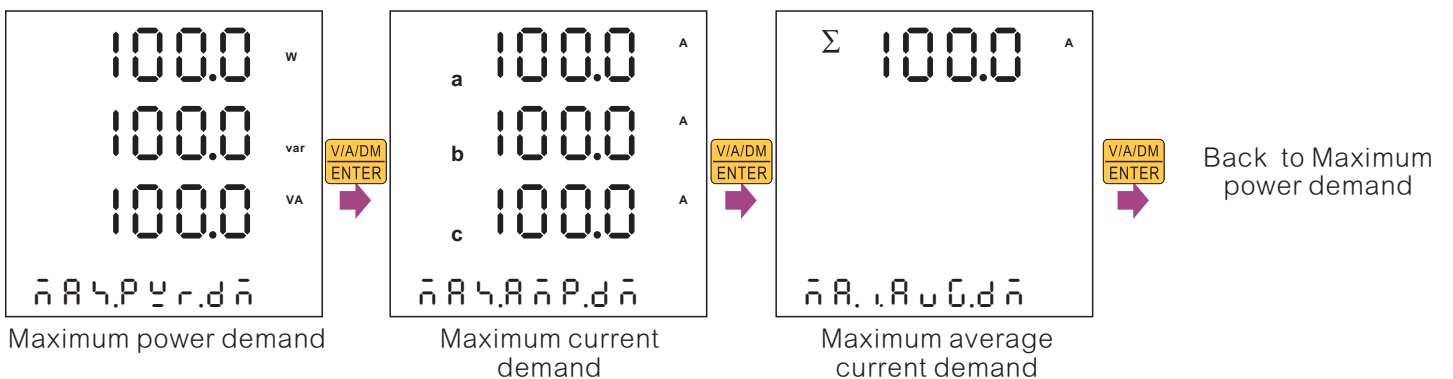

Model \ Optional \ Version display

Press +

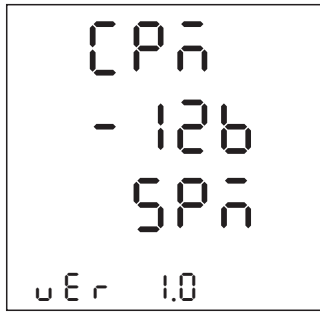

CPM-12B
5:5A input
P:Pulse output
M:RS485 Modbus
V1.0

5.Programming Setting

Parameters setting

:into setting or confirm setting : Press 2 sec back to previous menu or main display

Press +

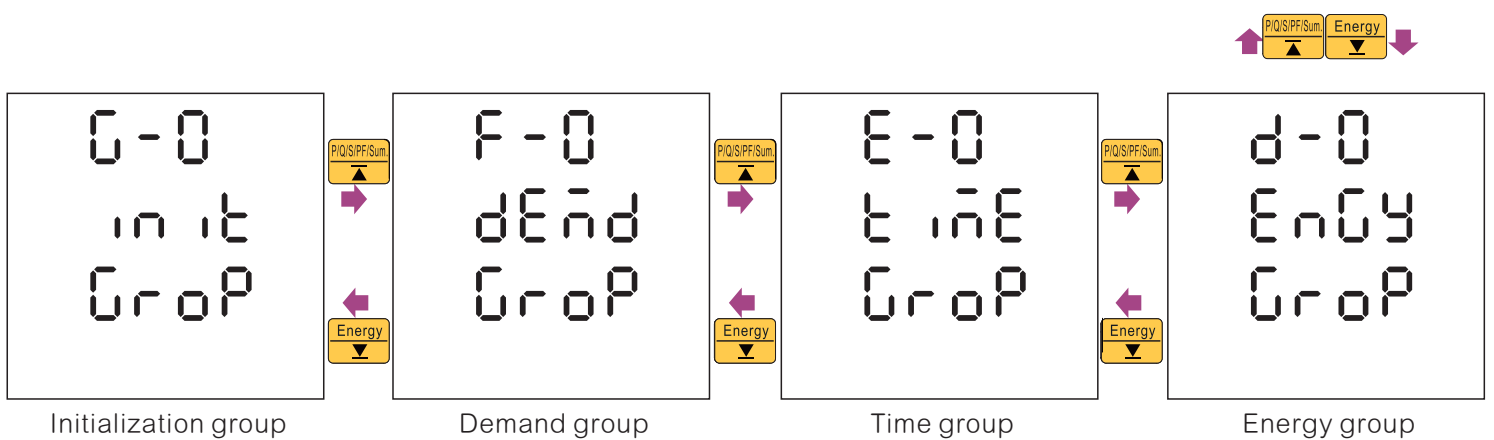
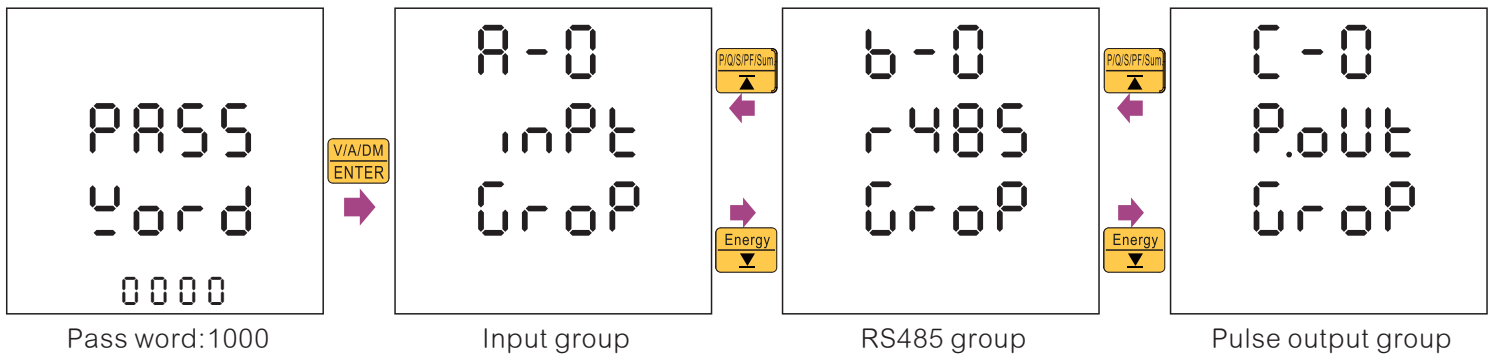

Back to A-0 input group

Input Group

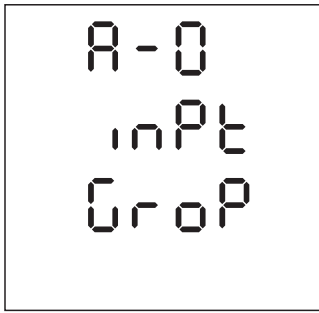

Input group



System type:
1P2W/1P3W/3P3W1CT/
3P3W2CT/3P3W3CT/3P4
W1CT/3P4W3CT

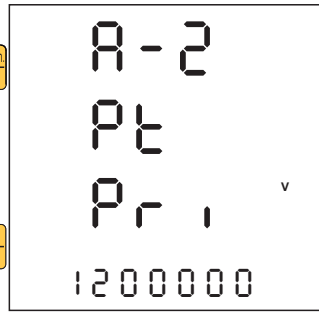

Voltage setting of
PT primary side
100~1200000V



Voltage setting of
PT second side
50~500V



Main display select
SUMMARY0~8

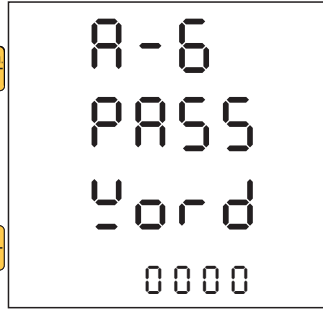

Password modify
0000~9999



Current setting of
CT secondary side
1A/5A/333mV
(If default is 333mV, it
cannot be changed)

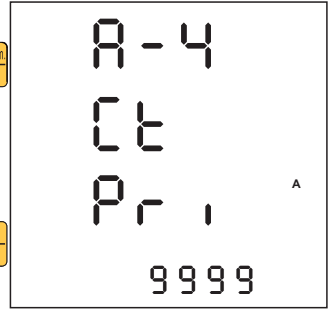

Current setting of
CT primary side
5~9999A

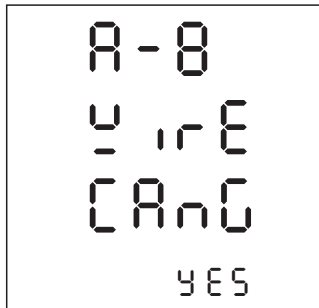

Auto wiring change
YES/NO

Refer the next page



Back to A-1
System
type

Auto wiring change

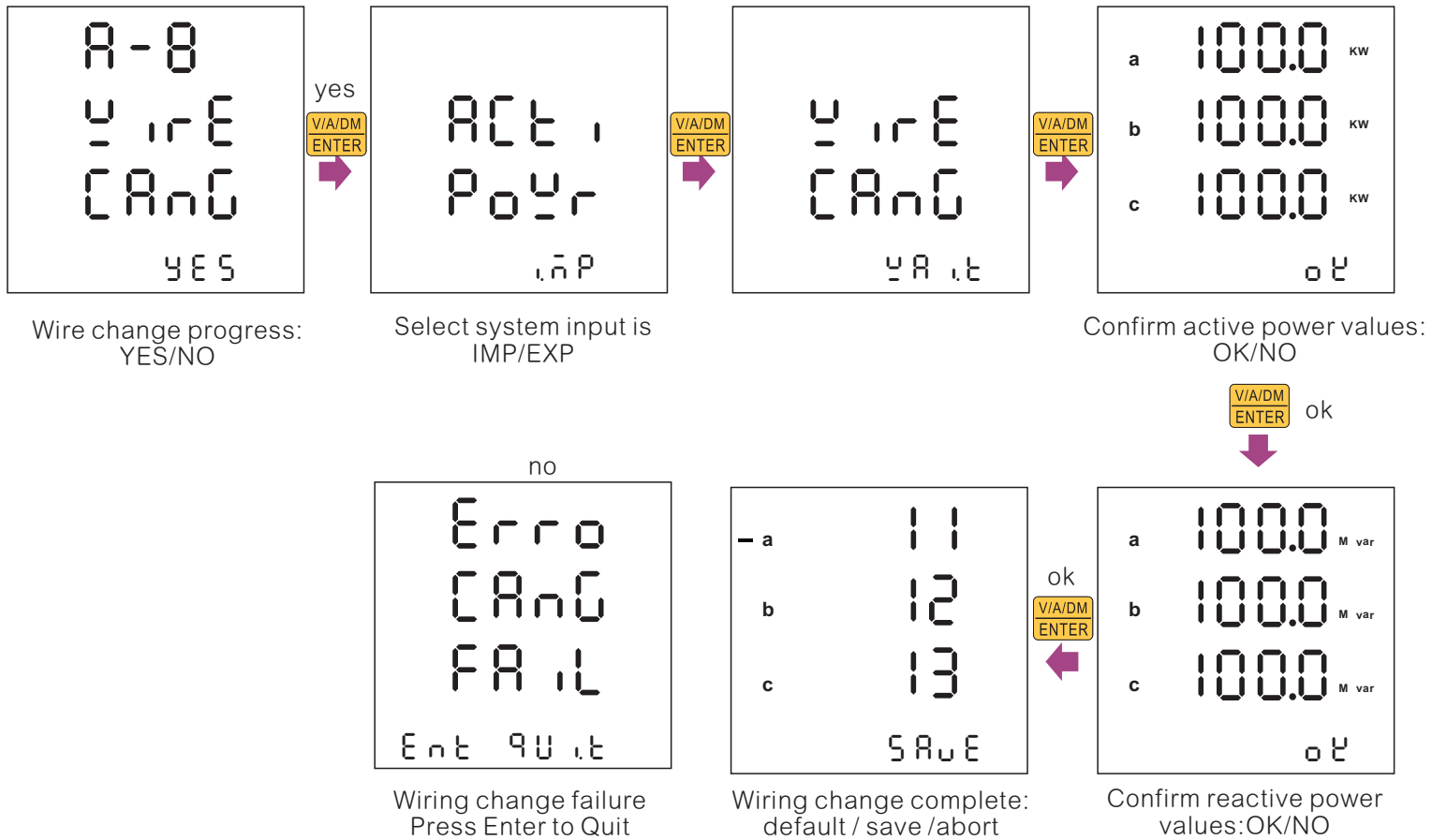

Auto wiring change condition limit :

- 3P4W-3CT : VN must be correct and $\theta < \pm 59^\circ$
- 3P4W-1CT : $\theta < \pm 59^\circ$
- 3P3W-2CT : V2 must be correct and $\theta < \pm 59^\circ$
- 3P3W-3CT : V2 must be correct and $\theta < \pm 59^\circ$
- 1P3W : VN must be correct and $\theta < \pm 59^\circ$
- 1P2W : $\theta < \pm 59^\circ$
- 3P3W-1CT: N/A

RS485 Group

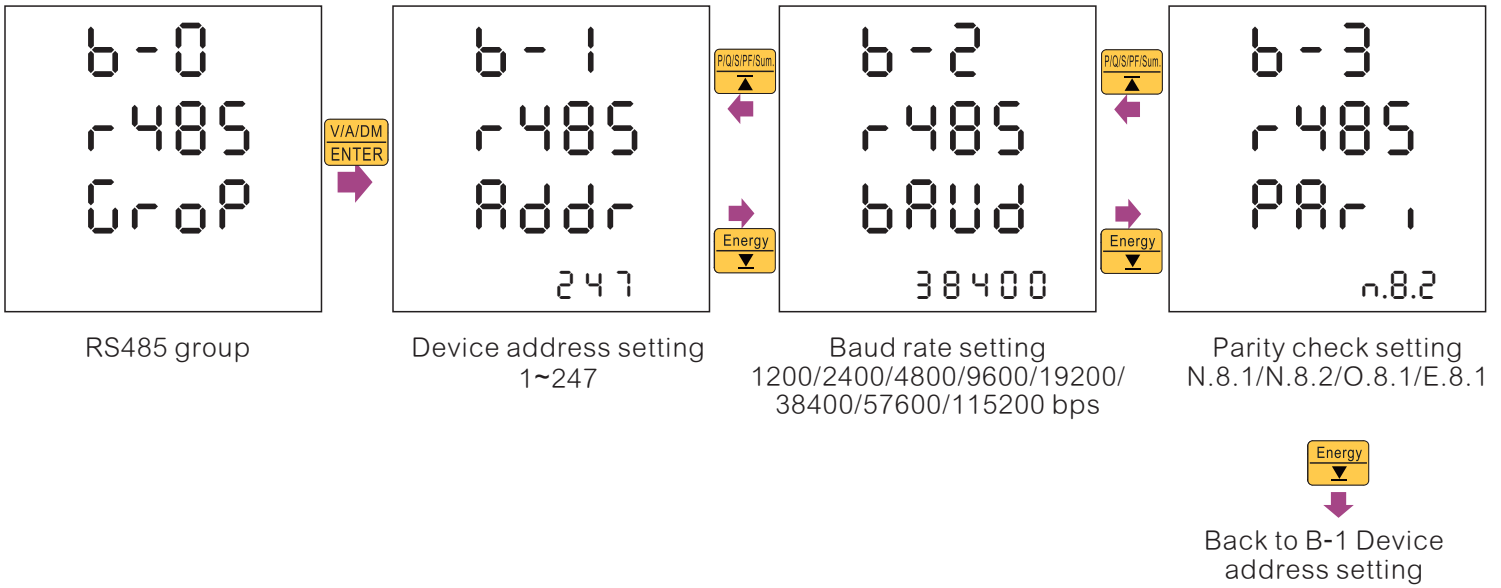

Pulse Output Group

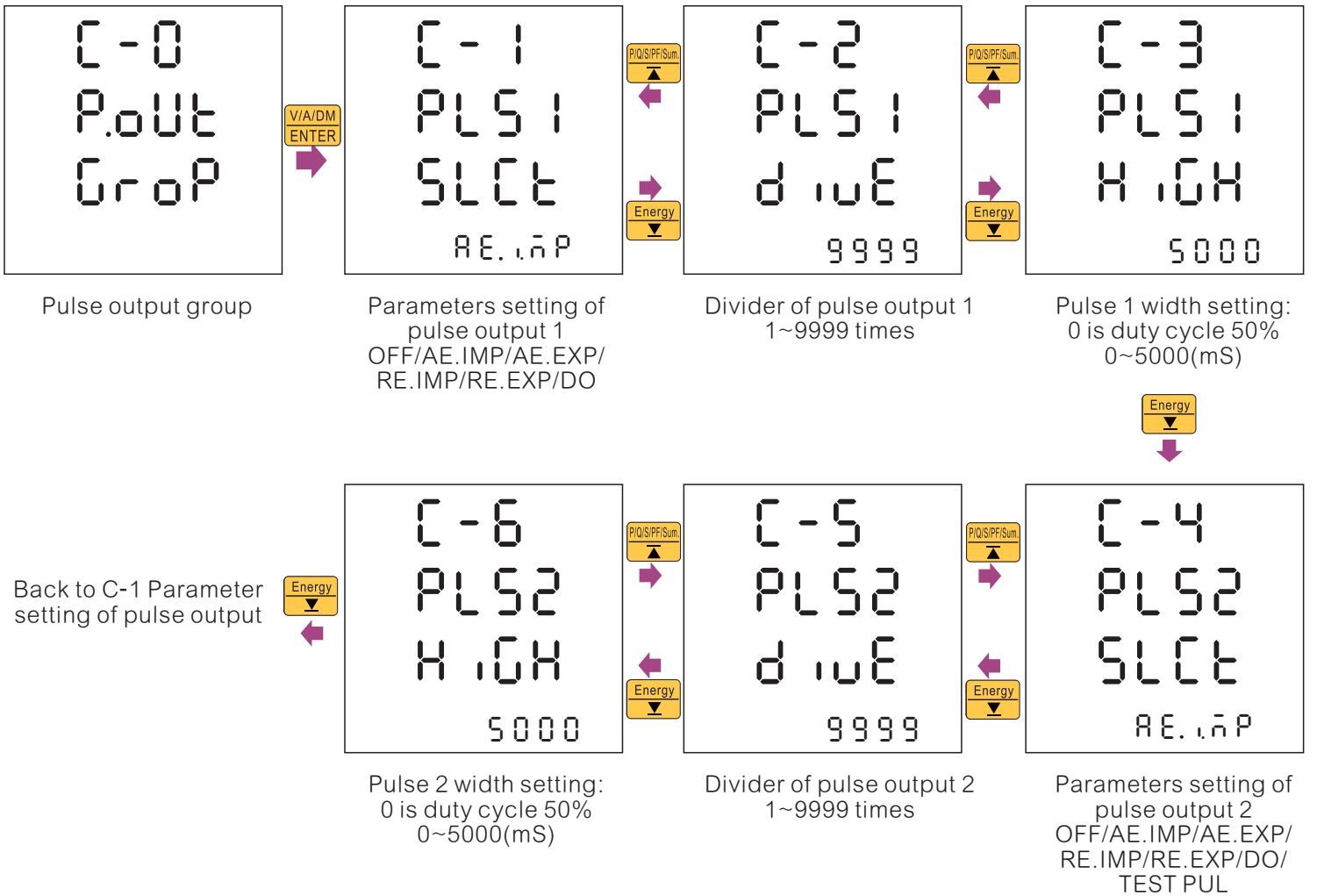

Energy Group

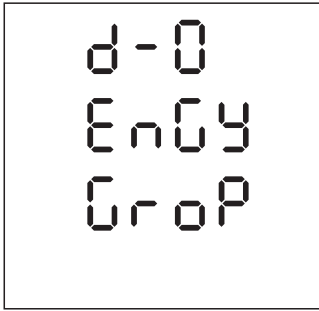

Energy group

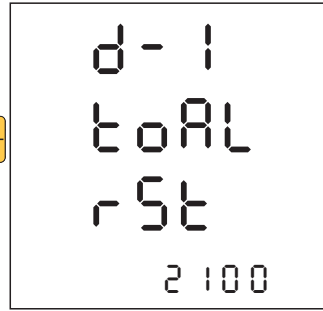

Reset active and reactive energy input password :2100

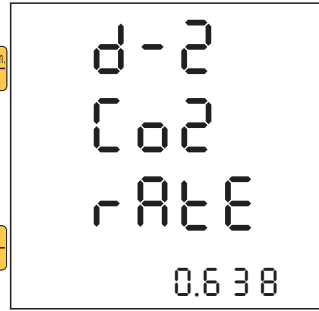

Total CO₂ weight of energy 00.000~60.000kg

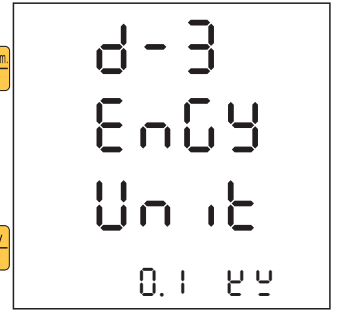

Energy unit
0.0001kWh / 0.001kWh
0.01kWh / 0.1kWh / 1kWh
/ 0.01MWh / 0.1MWh



Back to D-1 Reset energy

Time Group

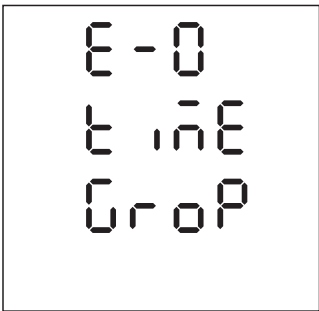

Time group

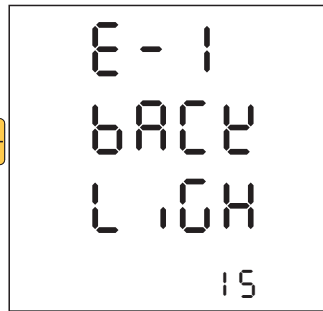

LCM backlight delay time setting
0~15Min,0 is always ON

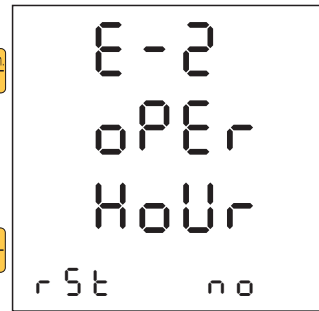

Reset operation time NO/YES

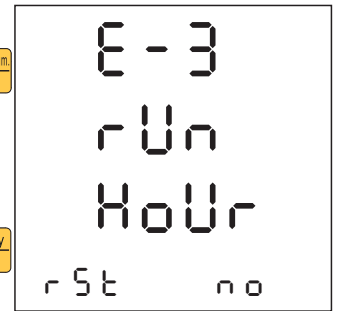

Reset running time NO/YES



Back to E-1 backlight delay time setting

Demand Group

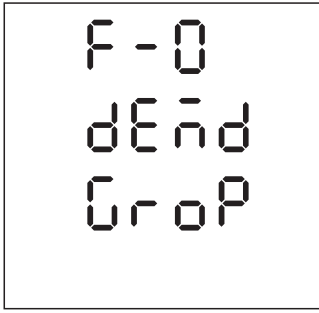

Demand Group

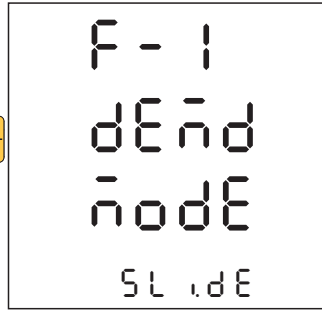

Calculation method:
SLIDE/FIX

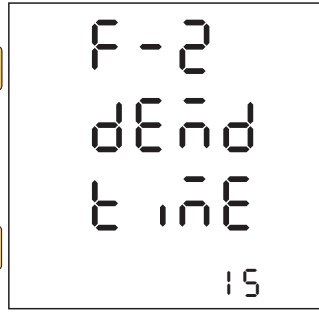

Demand interval time
setting:
1~60Min

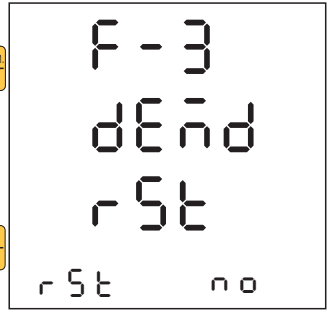

Reset demand:
NO/YES

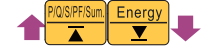

Back to F-1 Calculation method

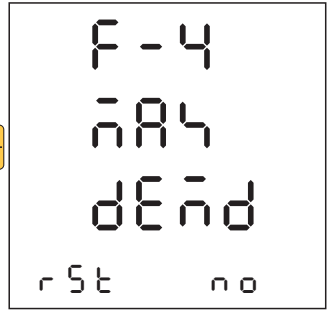

Reset Maximum demand:
NO/YES

Initial Group

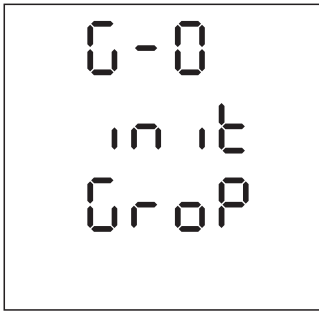

Initialization Group



Input password:
7170

7.RS485 Communication Table

System setting (Function code : 03h , 06h , 10h)

Input group

Parameter	Address	Range	Description	Default	Property
SYS WIRE	0000h	0~6	Metering system type 0: 1P2W 1: 1P3W 2: 3P3W1CT 3: 3P3W2CT 4: 3P3W3CT 5: 3P4W1CT 6: 3P4W3CT	6	R/W
PT PRI	0001h	100 ~ 1200000V	PT Primary side voltage(High Word)	500	R/W
	0002h		PT Primary side voltage(Low Word)		R/W
PT SEC	0003h	50~500V	PT Secondary side voltage	500	R/W
CT PRI	0004h	5~9999A (1~9999A)	CT Primary side current	5	R/W
PASS WORD	0005h	0000~9999	Password setting	1000	R/W
DISPLAY	0006h	0~8	Main summary display select 0: SUMMARY 3-PHASE 0 1: SUMMARY 3-PHASE 1 2: SUMMARY 3-PHASE 2 3: SUMMARY 3-PHASE 3 4: SUMMARY 3-PHASE 4 5: SUMMARY 3-PHASE 5 6: SUMMARY 3-PHASE 6 7: SUMMARY 3-PHASE 7 8: SUMMARY 3-PHASE 8	0	R/W
Data Config	0007h	0~3	bit 0: Floating data bit1 : Integer data 0: Big-Endian 1: Little-Endian	0	R/W
CT SEC	0008h	0~2	CT Secondary side current 0: 5A 1: 1A 2: 333mV	0	R/W

*CT secondary current (0008h), if 333mV is specified, this address cannot be written, can only be read, and the response value is fixed at 2.

RS485 communication setting

Parameter	Address	Range	Description	Default	Property
RS485 ADDR	002Ah	1~247	Device address setting	1	R/W
RS485 BAUD	002Bh	0~7	Baud rate 0:1200 1:2400 2:4800 3:9600 4:19200 5:38400 6:57600 7:115200 bps	3	R/W
RS485 PARI	002Ch	0~3	Parity Check 0:N,8,1 1:N,8,2 2:O,8,1 3:E,8,1	1	R/W

Pulse output setting

Parameter	Address	Range	Description	Default	Property
PULS1 SLCT	0037h	0~5	Parameter setting of pulse output 1 0:OFF 1: AE.IMP 2: AE.EXP 3: RE.IMP 4: RE.EXP 5:DO	1	R/W
PULS1 DIVE	0038h	1~9999	Divider of pulse output 1	1	R/W
PULS1 HIGH	0039h	0~5000 (mS)	Pulse 1 width setting ; 0 is duty cycle 50%	0	R/W
PULS2 SLCT	003Ah	0~6	Parameter setting of pulse output 2 0:OFF 1: AE.IMP 2: AE.EXP 3: RE.IMP 4: RE.EXP 5:DO 6: TEST PULSE	6	R/W
PULS2 DIVE	003Bh	1~9999	Divider of pulse output 2	1	R/W
PULS2 HIGH	003Ch	0~5000 (mS)	Pulse 2 width setting ; 0 is duty cycle 50%	0	R/W

Energy setting

Parameter	Address	Range	Description	Default	Property
TOAL RST	0048h	0~1	Reset Active, Reactive, Apparent energy and CO ₂ values 0:NO 1:YES	0	R/W
CO ₂ RATE	004Ah	00.000~60.000kg	Rate setting of CO ₂ weight per kWh	638	R/W
ENERGY UNIT	004Bh	0~6	Energy unit setting: 0: 0.0001kWh 1: 0.001kWh 2: 0.01kWh 3: 0.1kWh 4: 1kWh 5: 0.01MWh 6: 0.1MWh	3	R/W

Time setting

Parameter	Address	Range	Description	Default	Property
BACK LIGH	004Eh	0~15Min	LCM backlight delay time setting ; 0 is always ON	1	R/W
OPER HOUR RST	0055h	0~1	Reset operation time 0:NO 1:YES	0	R/W
RUN HOUR RST	0056h	0~1	Reset running time 0:NO 1:YES	0	R/W

Demand setting

Parameter	Address	Range	Description	Default	Property
DEMD MODE	005Bh	0~1	Calculation method: 0: SLIDE 1: FIX	0	R/W
DEMD TIME	005Ch	1~60Min	Demand interval time setting	15	R/W
DEMD RST	005Dh	0~1	Reset deman values 0:NO 1:YES	0	R/W
MAX DEMD RST	005Eh	0~1	Reset max demand values 0:NO 1:YES	0	R/W

Initialization setting

Parameter	Address	Range	Description	Default	Property
INIT	0062h	0000~9999	Write 7170 to restart and initialize the system and parameters to default status.	7170	W

Digital output status and control(Code : 01h , 05h):

Parameter	Address	Range	Description	Default	Property
DO1 STATUS & CONTROL	0000h		DO1 status and control 01h: 0:OFF 1: ON 05h: 0000h: OFF FF00h: ON		R/W
DO2 STATUS & CONTROL	0001h		DO2 status and control 01h: 0:OFF 1: ON 05h: 0000h: OFF FF00h: ON		R/W

Metering parameters reading(Code : 03h)

Parameter	Address	Range	Description	Default	Property
FREQ	0130h	45.00~65.00Hz	Frequency		R
U1	0131h	0.0 ~ 1200000.0V	Phase1 voltage (High Word)		R
	0132h		Phase1 voltage(Low Word)		R
U2	0133h	0.0 ~ 1200000.0V	Phase2 voltage(High Word)		R
	0134h		Phase2 voltage(Low Word)		R
U3	0135h	0.0 ~ 1200000.0V	Phase3 voltage(High Word)		R
	0136h		Phase3 voltage(Low Word)		R
ULN.AVG	0137h	0.0 ~ 1200000.0V	Average phase voltage(High Word)		R
	0138h		Average phase voltage(Low Word)		R
U12	0139h	0.0 ~ 1200000.0V	Phase1 line voltage (High Word)		R
	013Ah		Phase1 line voltage (Low Word)		R
U23	013Bh	0.0 ~ 1200000.0V	Phase2 line voltage(High Word)		R
	013Ch		Phase2 line voltage(Low Word)		R
U31	013Dh	0.0 ~ 1200000.0V	Phase3 line voltage(High Word)		R
	013Eh		Phase3 line voltage(Low Word)		R
ULL.AVG	013Fh	0.0 ~ 1200000.0V	Average line voltage(High Word)		R
	0140h		Average line voltage(Low Word)		R
I1	0141h	0.000~9999.999A	I1 current(High Word)		R
	0142h		I1 current(Low Word)		R
I2	0143h	0.000~9999.999A	I2 current(High Word)		R
	0144h		I2 current(Low Word)		R
I3	0145h	0.000~9999.999A	I3 current(High Word)		R
	0146h		I3 current(Low Word)		R
I.AVG	0147h	0.000~9999.999A	Average current(High Word)		R
	0148h		Average current(Low Word)		R
IN	0149h	0.000~9999.999A	Neutral current(High Word)		R
	014Ah		Neutral current(Low Word)		R
P-1	014Bh	-999999999~999999999W	Phase1 active power((High Word)		R
	014Ch		Phase1 active power(Low Word)		R
P-2	014Dh	-999999999~999999999W	Phase2 active power(High Word)		R
	014Eh		Phase2 phase active power(Low Word)		R
P-3	014Fh	-999999999~999999999W	Phase3 active power(High Word)		R
	0150h		Phase3 active power(Low Word)		R
P.SUM	0151h	-999999999~999999999W	Total active power(High Word)		R
	0152h		Total active power(Low Word)		R
Q-1	0153h	-999999999~999999999VAR	Phase1 reactive power((High Word)		R
	0154h		Phase1 reactive power(Low Word)		R
Q-2	0155h	-999999999~999999999VAR	Phase2 reactive power(High Word)		R
	0156h		Phase2 reactive power(Low Word)		R
Q-3	0157h	-999999999~999999999VAR	Phase3 reactive power(High Word)		R
	0158h		Phase3 reactive power(Low Word)		R
Q.SUM	0159h	-999999999~999999999VAR	Total reactive power(High Word)		R
	015Ah		Total reactive power(Low Word)		R
S-1	015Bh	0~999999999VA	Phase1 apparent power(High Word)		R
	015Ch		Phase1 apparent power(Low Word)		R
S-2	015Dh	0~999999999VA	Phase2 apparent power(High Word)		R
	015Eh		Phase2 apparent power(Low Word)		R
S-3	015Fh	0~999999999VA	Phase3 apparent power(High Word)		R
	0160h		Phase3 apparent power(Low Word)		R
S.SUM	0161h	0~999999999VA	Total apparent power(High Word)		R
	0162h		Total apparent power(Low Word)		R

Parameter	Address	Range	Description	Default	Property
PF1	0163h	-0.020~+1.000~0.020	Phase1 power factor		R
PF2	0164h	-0.020~+1.000~0.020	Phase2 power factor		R
PF3	0165h	-0.020~+1.000~0.020	Phase3 power factor		R
PF.AVG	0166h	-0.020~+1.000~0.020	Average Power Factor		R
Uunbl	0167h	0~300.0%	Voltage unbalance		R
Iunbl	0168h	0~300.0%	Current unbalance		R
P.DM.	016Ah	-999999999~999999999W	Total active power demand(High Word)		R
	016Bh		Total active power demand(Low Word)		R
Q.DM.	016Ch	-999999999~999999999VAR	Total reactive power demand(High Word)		R
	016Dh		Total reactive power demand(Low Word)		R
S.DM.	016Eh	0 ~ 999999999VA	Total apparent power demand(High Word)		R
	016Fh		Total apparent power demand(Low Word)		R
I1.DM.	0170h	0.000~9999.999A	I1 current demand(High Word)		R
	0171h		I1 current demand(Low Word)		R
I2.DM.	0172h	0.000~9999.999A	I2 current demand(High Word)		R
	0173h		I2 current demand(Low Word)		R
I3.DM.	0174h	0.000~9999.999A	I3 current demand(High Word)		R
	0175h		I3 current demand(Low Word)		R
I.AVG.DM.	0176h	0.000~9999.999A	Average current demand(High Word)		R
	0177h		Average current demand(Low Word)		R

Parameter	Address	Range	Description	Default	Property
AE-IMP	0181h	0.0~9999999.9kWh	Import active energy(High Word)		R
	0182h		Import active energy(Low Word)		R
AE-EXP	0183h	0.0~9999999.9kWh	Export active energy(High Word)		R
	0184h		Export active energy(Low Word)		R
AE-Total	0185h	0.0~9999999.9kWh	Total active energy(High Word)		R
	0186h		Total active energy(Low Word)		R
AE-Net	0187h	-999999.9~9999999.9kWh	Net active energy(High Word)		R
	0188h		Net active energy(Low Word)		R
RE-IMP	0189h	0.0~9999999.9kVARh	Import reactive energy(High Word)		R
	018Ah		Import reactive energy(Low Word)		R
RE-Exp	018Bh	0.0~9999999.9kVARh	Export reactive energy(High Word)		R
	018Ch		Export reactive energy(Low Word)		R
RE-Total	018Dh	0.0~9999999.9kVARh	Total reactive energy(High Word)		R
	018Eh		Total reactive energy(Low Word)		R
RE-Net	018Fh	-999999.9~9999999.9kVARh	Net reactive energy(High Word)		R
	0190h		Net reactive energy(Low Word)		R
SE-Total	0191h	0.0~9999999.9kVAh	Total apparent energy(High Word)		R
	0192h		Total apparent energy(Low Word)		R

Parameter	Address	Range	Description	Default	Property
CO ₂	0195h	0.000~99999.999kg	Total CO ₂ weight of energy(High Word)		R
	0196h		Total CO ₂ weight of energy(Low Word)		R

Parameter	Address	Range	Description	Default	Property
OPERATING HOUR	0198h	0~599999999Min	Operation time(High Word)		R
	0199h		Operation time(Low Word)		R
RUN HOUR	019Ah	0~599999999Min	Running time(High Word)		R
	019Bh		Running time(Low Word)		R

Parameter	Address	Range	Description	Default	Property
U1(U12).THD	029Fh	0.0~100.0%	U1(U12) total harmonic of voltage		R
U2(U23).THD	02A0h	0.0~100.0%	U2(U23) total harmonic of voltage		R
U3(U31).THD	02A1h	0.0~100.0%	U3(U31) total harmonic of voltage		R
UAVG.THd	02A2h	0.0~100.0%	Average total harmonic of voltage		R
I1.THd	02A3h	0.0~100.0%	I1 total harmonic of current		R
I2.THd	02A4h	0.0~100.0%	I2 total harmonic of current		R
I3.THd	02A5h	0.0~100.0%	I3 total harmonic of current		R
Iavg.THd	02A6h	0.0~100.0%	Average total harmonic of current		R

Parameter	Address	Range	Description	Default	Property
P.DM.MAX	04DDh	-999999999~999999999W	Maximum total active power demand (High Word)		R
	04DEh		Maximum total active power demand(Low Word)		R
Q.DM.MAX	04E5h	-999999999~999999999VAR	Maximum total reactive power demand(High Word)		R
	04E6h		Maximum total reactive power demand(Low Word)		R
S.DM.MAX	04EDh	0 ~ 999999999VA	Maximum total apparent power demand(High Word)		R
	04EEh		Maximum total apparent power demand(Low Word)		R
I1.DM.MAX	04F5h	0.000~9999.999A	Maximum I1 current demand(High Word)		R
	04F6h		Maximum I1 current demand(Low Word)		R
I2.DM.MAX	04FDh	0.000~9999.999A	Maximum I2 current demand(High Word)		R
	04FEh		Maximum I2 current demand(Low Word)		R
I3.DM.MAX	0505h	0.000~9999.999A	Maximum I3 current demand(High Word)		R
	0506h		Maximum I3 current demand(Low Word)		R
I.AVG.DM.MAX	050Dh	0.000~9999.999A	Maximum iverage current demand(High Word)		R
	050Eh		Maximum iverage current demand(Low Word)		R
P.DM.MIN	0515h	-999999999~999999999W	Minimum total active power demand (High Word)		R
	0516h		Minimum total active power demand(Low Word)		R
Q.DM.MIN	051Dh	-999999999~999999999VAR	Minimum total reactive power demand(High Word)		R
	051Eh		Minimum total reactive power demand(Low Word)		R
S.DM.MIN	0525h	0 ~ 999999999VA	Minimum total apparent power demand(High Word)		R
	0526h		Minimum total apparent power demand(Low Word)		R

Parameter	Address	Range	Description	Default	Property
Phasor Diagram V2 lag V1	052Dh	0~360.0	Phasor Diagram V2 lag V1		R
Phasor Diagram V3 lag V1	052Eh	0~360.0	Phasor Diagram V3 lag V1		R
Phasor Diagram I1 lag V1	052Fh	0~360.0	Phasor Diagram I1 lag V1		R
Phasor Diagram I2 lag V1	0530h	0~360.0	Phasor Diagram I2 lag V1		R
Phasor Diagram I3 lag V1	0531h	0~360.0	Phasor Diagram I3 lag V1		R
Phasor Diagram V23 lag V12	0532h	0~360.0	Phasor Diagram V23 lag V12		R
Phasor Diagram V31 lag V12	0533h	0~360.0	Phasor Diagram V31 lag V12		R
Phasor Diagram I1 lag V12	0534h	0~360.0	Phasor Diagram I1 lag V12		R
Phasor Diagram I2 lag V12	0535h	0~360.0	Phasor Diagram I2 lag V12		R
Phasor Diagram I3 lag V12	0536h	0~360.0	Phasor Diagram I3 lag V12		R

User define setting(Code : 03h, 06h, 10h)

Parameter	Address	Range	Description	Default	Property
U.DF01P	5000h	0130h~0177h 0181h~019Bh 029Fh~02A6h	Parameters address assignment	0130h	R/W
U.DF02P	5001h			0131h	R/W
U.DF03P	5002h			0132h	R/W
U.DF04P	5003h			0133h	R/W
U.DF05P	5004h			0134h	R/W
U.DF06P	5005h			0135h	R/W
U.DF07P	5006h			0136h	R/W
U.DF08P	5007h			0137h	R/W
U.DF09P	5008h			0138h	R/W
U.DF10P	5009h			0139h	R/W
U.DF11P	500Ah			013Ah	R/W
U.DF12P	500Bh			013Bh	R/W
U.DF13P	500Ch			013Ch	R/W
U.DF14P	500Dh			013Dh	R/W
U.DF15P	500Eh			013Eh	R/W
U.DF16P	500Fh			013Fh	R/W
U.DF17P	5010h			0140h	R/W
U.DF18P	5011h			0141h	R/W
U.DF19P	5012h			0142h	R/W
U.DF20P	5013h			0143h	R/W
U.DF01V	5014h		Reading of parameters		R
U.DF02V	5015h				R
U.DF03V	5016h				R
U.DF04V	5017h				R
U.DF05V	5018h				R
U.DF06V	5019h				R
U.DF07V	501Ah				R
U.DF08V	501Bh				R
U.DF09V	501Ch				R
U.DF10V	501Dh				R
U.DF11V	501Eh				R
U.DF12V	501Fh				R
U.DF13V	5020h				R
U.DF14V	5021h				R
U.DF15V	5022h				R
U.DF16V	5023h				R
U.DF17V	5024h		R		
U.DF18V	5025h		R		
U.DF19V	5026h		R		
U.DF20V	5027h		R		

User define field function description:

This function is let users to read the value of the parameters of what to be read at once time.

Will be read of the parameters register code fill in 5000h ~ 5013h then can read the value of the parameters from 5014h~5027h

For example:

If 0131h write to 5000h (High word register of U1 phase voltage) , and 0132h write to 5001h (Low word register of U1 phase voltage)
Read 5014h and 5015h are value of U1 phase voltage .

Floating data(Function code : 03h):

Parameter	Address	Range	Description	Default	Property
FREQ	7000h	45.00~65.00Hz	Frequency		R
	7001h				
U1	7002h	0.0 ~ 1200000.0 V	Phase1 voltage		R
	7003h				
U2	7004h	0.0 ~ 1200000.0 V	Phase2 voltage		R
	7005h				
U3	7006h	0.0 ~ 1200000.0 V	Phase3 voltage		R
	7007h				
ULN.AVG	7008h	0.0 ~ 1200000.0 V	Average phase voltage		R
	7009h				
U12	700Ah	0.0 ~ 1200000.0 V	Phase1 line voltage		R
	700Bh				
U23	700Ch	0.0 ~ 1200000.0 V	Phase2 line voltage		R
	700Dh				
U31	700Eh	0.0 ~ 1200000.0 V	Phase3 line voltage		R
	700Fh				
ULL.AVG	7010h	0.0 ~ 1200000.0 V	Average line voltage		R
	7011h				
I1	7012h	0.000~9999.999A	I1 current		R
	7013h				
I2	7014h	0.000~9999.999A	I2 current		R
	7015h				
I3	7016h	0.000~9999.999A	I3 current		R
	7017h				
I.AVG	7018h	0.000~9999.999A	Average current		R
	7019h				
IN	701Ah	0.000~9999.999A	Neutral current		R
	701Bh				
P-1	701Ch	-999999999~999999999W	Phase1 active power		R
	701Dh				
P-2	701Eh	-999999999~999999999W	Phase2 active power		R
	701Fh				
P-3	7020h	-999999999~999999999W	Phase3 active power		R
	7021h				
P.SUM	7022h	-999999999~999999999W	Total active power		R
	7023h				
Q-1	7024h	-999999999~999999999VAR	Phase1 reactive power		R
	7025h				
Q-2	7026h	-999999999~999999999VAR	Phase2 reactive power		R
	7027h				
Q-3	7028h	-999999999~999999999VAR	Phase3 reactive power		R
	7029h				
Q.SUM	702Ah	-999999999~999999999VAR	Total reactive power		R
	702Bh				
S-1	702Ch	0~999999999VA	Phase1 apparent power		R
	702Dh				
S-2	702Eh	0~999999999VA	Phase2 apparent power		R
	702Fh				
S-3	7030h	0~999999999VA	Phase3 apparent power		R
	7031h				
S.SUM	7032h	0~999999999VA	Total apparent power		R
	7033h				
PF1	7034h	-0.020~+1.000~0.020	Phase1 power factor		R
	7035h				
PF2	7036h	-0.020~+1.000~0.020	Phase2 power factor		R
	7037h				
PF3	7038h	-0.020~+1.000~0.020	Phase3 power factor		R
	7039h				
PF.AVG	703Ah	-0.020~+1.000~0.020	Average Power Factor		R
	703Bh				
Uunbl	703Ch	0~300.0%	Voltage unbalance		R
	703Dh				
Iunbl	703Eh	0~300.0%	Current unbalance		R
	703Fh				

Parameter	Address	Range	Description	Default	Property
P.DM.	7042h	-999999999 ~ 999999999W	Total active power demand		R
	7043h				
Q.DM.	7044h	-999999999 ~ 999999999VAR	Total reactive power demand		R
	7045h				
S.DM.	7046h	0 ~ 999999999VA	Total apparent power demand		R
	7047h				
I1.DM.	7048h	0.000~9999.999A	I1 current demand		R
	7049h				
I2.DM.	704Ah	0.000~9999.999A	I2 current demand		R
	704Bh				
I3.DM.	704Ch	0.000~9999.999A	I3 current demand		R
	704Dh				
I.AVG.DM.	704Eh	0.000~9999.999A	Average current demand		R
	704Fh				
U1(U12).THD	7050h	0.0~100.0%	U1(U12) total harmonic of voltage		R
	7051h				
U2(U23).THD	7052h	0.0~100.0%	U2(U23) total harmonic of voltage		R
	7053h				
U3(U31).THD	7054h	0.0~100.0%	U3(U31) total harmonic of voltage		R
	7055h				
UAVG.TH D	7056h	0.0~100.0%	Average total harmonic of voltage		R
	7057h				
I1.TH D	7058h	0.0~100.0%	I1 total harmonic of current		R
	7059h				
I2.TH D	705Ah	0.0~100.0%	I2 total harmonic of current		R
	705Bh				
I3.TH D	705Ch	0.0~100.0%	I3 total harmonic of current		R
	705Dh				
IAVG.TH D	705Eh	0.0~100.0%	Average total harmonic of current		R
	705Fh				
AE-IMP	7060h	0.0~9999999.9kWh	Import active energy		R
	7061h				
AE-Exp	7062h	0.0~9999999.9kWh	Export active energy		R
	7063h				
AE-Total	7064h	0.0~9999999.9kWh	Total active energy		R
	7065h				
AE-Net	7066h	-999999.9~9999999.9kWh	Net active energy		R
	7067h				
RE-IMP	7068h	0.0~9999999.9kVARh	Import reactive energy		R
	7069h				
RE-Exp	706Ah	0.0~9999999.9kVARh	Export reactive energy		R
	706Bh				
RE-Total	706Ch	0.0~9999999.9kVARh	Total reactive energy		R
	706Dh				
RE-Net	706Eh	-999999.9~9999999.9kVARh	Net reactive energy		R
	706Fh				
SE-Total	7070h	0.0~9999999.9kVAh	Total apparent energy		R
	7071h				
CO ₂	7072h	0.000~99999.999kg	Total CO ₂ weight of energy		R
	7073h				